

Product Description

Alec Smart Lighting Conversion (SLC2-LR) kit is a new, low-cost solution that instantly convert any of your linear fluorescent lighting fixture into efficient, eco-friendly Smart LED lighting. An SLC2-LR comprises:

- A fluorescent to LED retrofit kits (part number RF1-xxx)**
 - Certified to UL-1598C/ CSA-C22.2 No. 250.13
 - All components magnetically attached
 - Color temperature options 3500 to 5000K
 - Retrofits 2', 4', 8' linear or u-shaped fluorescent
 - Eliminates disposal of existing fixture body
 - Quick connectors for all electrical connections
 - Typically installed in < 10 minutes
- A smart LED lighting controller (part number LC2-LR),**
 - Certified to UL 8750 & C22.2 250.13-17 standard
 - Integrated long range (40' / 12m) PIR occupancy sensor and daylight lux metering sensor.
 - Provides on-demand lighting while minimizing energy waste.
 - Magnetically attached to the fixture or the ceiling.
 - All control settings fully programmable via USB port.
 - Programmable via handheld Infrared Remote**

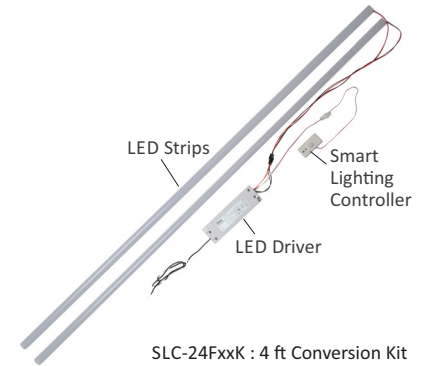

Physical Dimensions

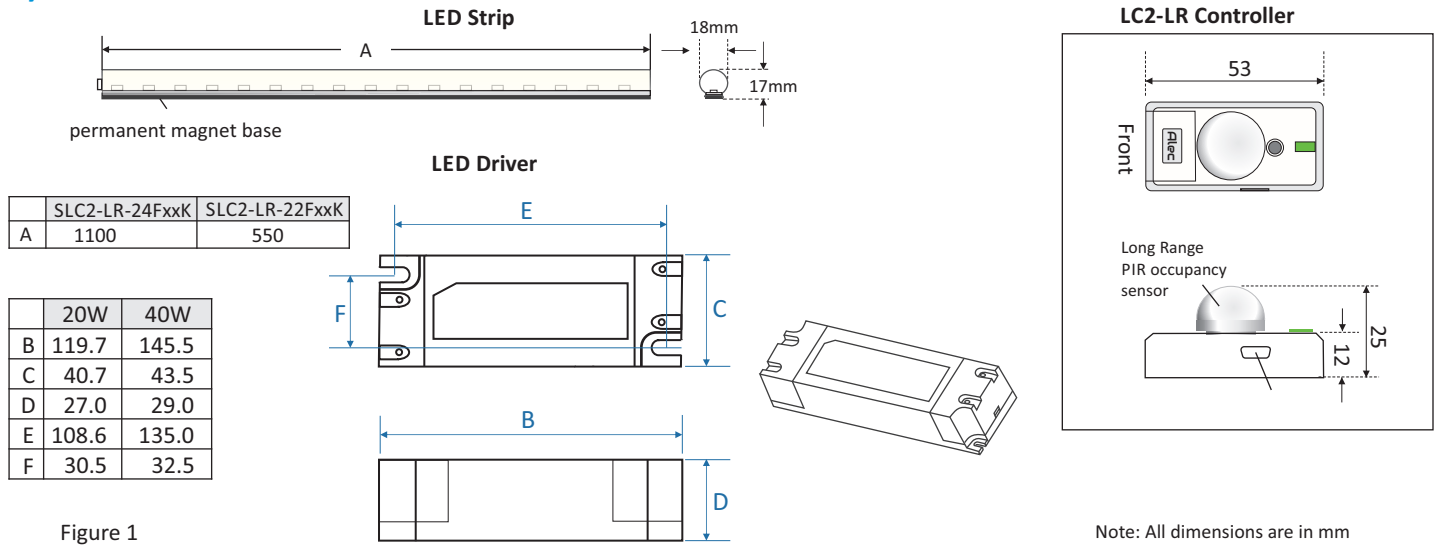

Figure 1

LC2-LR Features

- Long Range PIR Occupancy / Vacancy Sensor** - Auto-dims LED lights when vacant. Brightens immediately when occupied. All timings are fully programmable. The occupancy sensor has a long range of 12m (40ft) and adequately covers the area below the converted fixture as shown in Figure 2.
- Daylight Harvesting Sensor** - Auto-dims LED lights proportionally to daylight.
- Dual-Stage Dimming** - Ensures lights will never be turned OFF unexpectedly.
- Comply to Energy Codes** - ASHRAE 90.1, NECB, IECC or Title 24
- User-Adjustable Working Brightness** - via handheld remote control unit instead of the trim pots deployed in LC1.

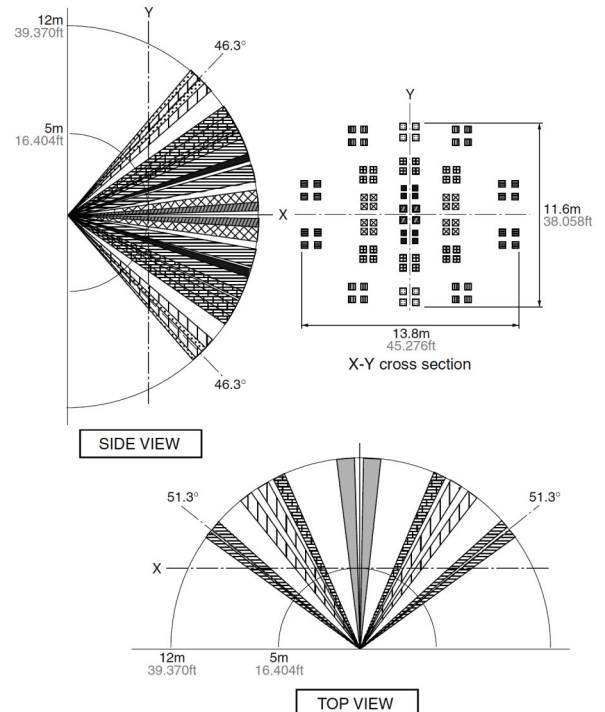

Figure 2: LC2-LR PIR occupancy sensor range

LC2-LR Specifications

Power Supply	Input voltage	25V to 42.4V DC, Max=55VDC (Class 2)
	Input current / power	10 ~ 20mA DC / 0.25W
Dimming Output	Output voltage	0V to 10V DC
	Output current	Up to 10mA DC (source or sink)
Operating Environment	Installation Location	Dry Location only
	Operating Temperature	-20°C to 50°C
Magnetic Backing	Magnetic Material	NdFeB
	Magnetic Field Strength	1500 Gs (150 mT) min, 80°C.
Dimensions & Weight	Dimensions	2.1" (L) x 1.05" (W) x 0.46" (H)
	Weight	0.67oz (19g)

Programming LC2-LR via USB Port

The fully programmable LC2-LR Smart Lighting Controller included with every SLC2-LR is very simple to setup. Just connect a PC or an Android smart phone to the LC2-LR using a USB cable (and a USB-OTG adapter if using Android), and select one of the pre-defined profiles. Then click the "Write Settings" button on the screen, and the controller is setup and ready to deploy. You can further fine-tune every configurable parameter for special applications.

Note: LC2-LR can be powered by the USB cable directly for programming purpose and hence can be configured quickly without being installed first. When installing on-site, the installer can simply connect the LC2-LR to the Android phone app, program it within seconds, and then installing it onto the ceiling.

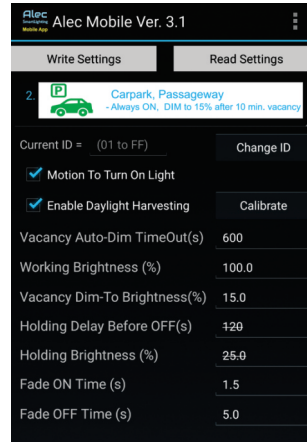

Figure 3a: Alec Mobile App

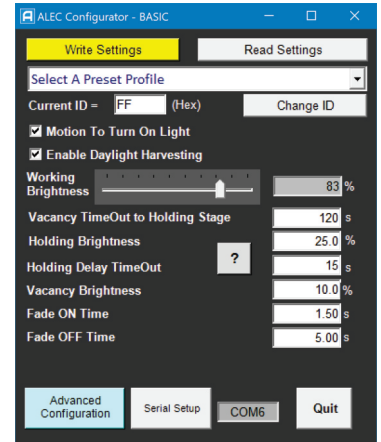

Figure 3b: Alec PC Config. App

Programming LC2-LR Using The IR Remote Control

A special IR remote controller (part number ARC-044) allows the installer to remotely program the LC2-LR controller from the floor after the fixture and LC2-LR has been installed on the ceiling. You can program the working brightness, vacancy brightness, vacancy time-out, holding brightness and holding relays, etc.

Importantly, there are 4 buttons on the top row of the ARC-044 are used to set up the LC2-LR controller to use pre-set profiles. It is truly a one-button commissioning tool for the most common application types. These are: Stairwells (and corridors), car park (and passage way), enclosed space (e.g. offices, bathroom) and open offices.

You can make further changes (such as changing the vacancy light level, time-out etc) using the quick settings or the advanced settings buttons) after selecting the preset profile.



LC2-LR Dual Stage Dimming

LC2-LR uses dual-stage, super-fine dimming process (See Figure 4) to greatly enhance user experience. Every parameter in the process (including Fade ON and Fade OFF speed) is configurable via software. User can also adjust the appropriate working brightness that suits the space, instead of having 100% brightness at all times. This eliminates over- or under-lighting that can affect safety or worker productivity.

LC2-LR also employs continuous, closed-loop control algorithm to adjust the dimming level of the light in response to the amount of daylight reflected from the space below it. This ensures that the space will always receive adequate amount of light without user intervention.

A Smart LED light created from an SLC-LR can provide better and brighter lighting on-demand, while saving energy through improved efficiency and reduced energy waste.

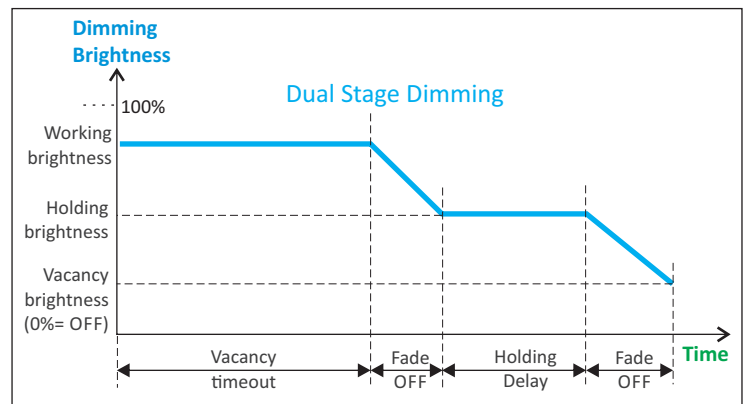

Figure 4

Wiring Diagram

- 1) Connect the L (Black) and N (white) wires from the LED driver to the AC mains.
- 2) Put the LED strips in place and connect their power to the LED driver using the supplied quick connectors.
- 3) Connect the LC2-LR Smart Lighting Controller to the LED driver using another quick connector. Then position the LC2-LR to a suitable location on the fixture body or the T-bar of suspended ceilings.

View installation instructions at: www.aleccontrol.com/slc#igs

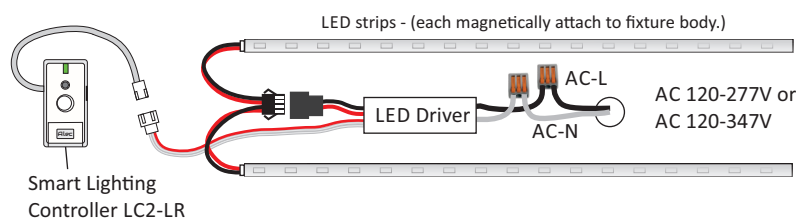

Figure 5: SLC components & Wiring Diagram

Photometric Measurement (From LM79-08)

RF1-24F40WD35K Stand Alone

Voltage (V)	Frequency (Hz)	Current (A)	Power (W)	Power Factor	Luminous Flux(lm)	Efficacy (lm/W)
120.0	60	0.3572	42.2	0.9846	5582	132.28

Radiant Flux (W)	CCT (K)	Duv	x	y	u'	v'
16.892	3436	-0.00085	0.4080	0.3901	0.2377	0.5114

Color Rendering Index

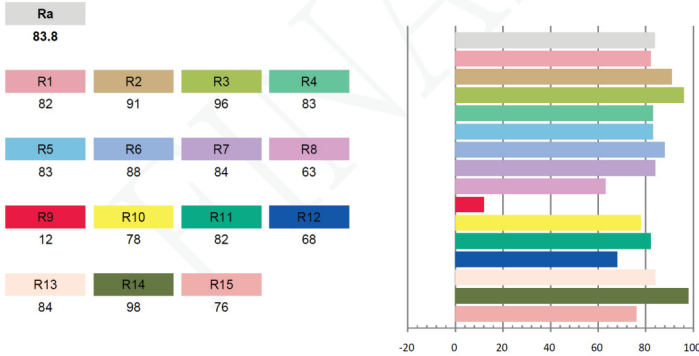

RF1-24F40WD35K Retrofitted Inside a Troffer

Luminous Flux (lm)	Efficacy (lm/W)	I _{max} (cd)	S/MH (C0/180)	S/MH (C90/270)
4627.9	109.54	1964.6	1.20	1.25

Luminous Intensity Distribution

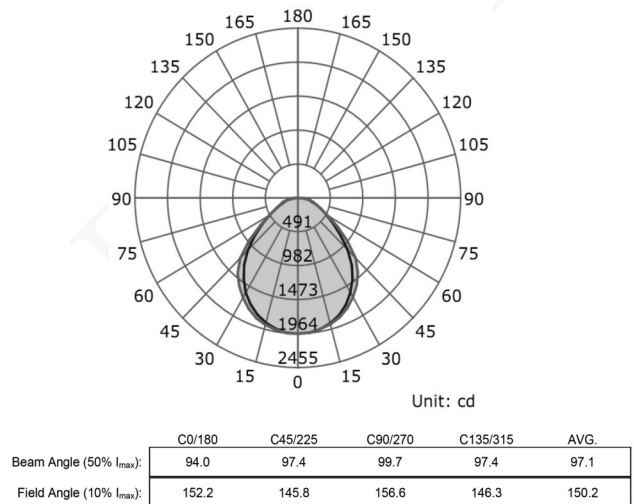

SLC Model Guide and Luminaire Specifications

Item	SLC Model	*SLC2-LR-14FxxK	SLC2-LR-24FxxK	SLC2-LR-22FxxK	SLC2-LR-24FxxK-347V
Retrofit Kit Model		RF1-14F20WDxxK	RF1-24F40WDxxK	RF1-22F20WDxxK	RF1-24F40WD-347VxxK
LED strip Dimensions x Qty		(1100mm*18mm) x 1pc (43.3" x 0.7") x 1pc	(1100mm*18mm) x 2pcs (43.3" * 0.7") x 2pcs	(550mm*18mm) x 2pcs (21.7"*0.7") x 2pcs	(1100mm*18mm) x 2pcs (43.3" * 0.7") x 2pcs
Input Voltage (Frequency)		100-277V (50/60Hz)	100-277V (50/60Hz)	100-277V(50/60Hz)	120-347V (50/60Hz)
Input Power Consumption (Power Factor)		20W (>= 0.9)	40W (>= 0.9)	20W (>= 0.9)	40W (>= 0.9)
Nominal Output Lumens @100%		2800	5700	2800	5700
Dimming signal		1-10V			
Color Rendering Index		> 80			
Color temperatures		xxK Suffix => 40K : 4000K. 50K : 5000K			
L70 Lifespan @100% output		50,000 hours			
Operating Enviroments		-20°C to +50°C. RH 20% - 85%, non-condensing. Dry Location			Damp location rated
Certifications & Warranty		UL, ETL, CSA, DLC, LM-79-08, FCC. 5 Years Limited Warranty (Parts Only)			

* Available on special request



Ordering Guide

